

WELCOME TO THE STUDIO



DS2 STUDIOS

VENTURA, CA.

A BOUTIQUE COMMERCIAL
& RESIDENTIAL INTERIOR
DESIGN FIRM

ABOUT US
OUR CLIENTS
OUR SERVICES

*"lets create something
beautiful"*

-sj

PHONE. (323)902-7088

EMAIL. Hello@ds2studios.com

WWW.DS2STUDIOS.COM

PROJECT PHOTO - BODY MET RX



TABLE OF CONTENTS

**STUDIO WELCOME
PACKAGE**

ABOUT OUR COMPANY	04
CLIENT TESTIMONIALS	06
SERVICES	07
CLIENT ON-BOARDING	11
DESIGN PROCESS	12
GLOSSARY OF DELIVERABLES	13
RATES	19

DS2 STUDIOS

A BOUTIQUE COMMERCIAL & RESIDENTIAL INTERIOR DESIGN FIRM, FOCUSED ON CREATING SPACES TAILORED TO YOUR LIFESTYLE AND BRAND.

AT DS2 STUDIOS WE WORK WITH BRANDS, AND HOME OWNERS, TO CREATE SPACES THAT NOT ONLY BOOST THEIR BOTTOM LINE, BUT PROVIDE AN EXPERIENCE FOR THEMSELVES AND/OR THEIR CUSTOMERS.



GETTING THE JOB DONE PROPERLY



100

PROJECTS SINCE
2014



98%

RATE US WITH 5 OUT
OF 5 STARS, THEY ARE
SATISFIED!



98%

OF OUR NEW PROJECTS
ARE REFERRALS OR
RETURNING CLIENTS.

DS2 STUDIOS

TEAM



SARAH JACOBSON

PRINCIPAL DESIGNER & FOUNDER

Sarah started her design journey at a young age, pursuing a Bachelors degree in interior design and starting her design firm right out of college. Her passions for both business and interior design originally lead her towards creating brand-centric designs for commercial clients. Working in this niche market helped develop and expand her skill set, and ultimately moved her towards partnering with homeowners on their journey to falling in love with their homes.

A FEW OF HER FAVORITES: COFFEE • TRAVEL • HER DOG ODIE



14

YEARS EXPERIENCE



2

REMOTE WORKER

WHAT CUSTOMERS THINK ABOUT US



MARLEY PAULUS

OWNER OF BODY MET RX

Working with DS2 was a seamless experience. They fully encapsulated our vision... We highly recommend working with them!



INEZ LAVAL

OWNER OF WXING BY INEZ

What can I say? They killed it! I told Sarah the colors of my business and gave her all creative control over the project. She came back with a concept that was PERFECT and allowed me to start fresh... I am so grateful to have found Sarah and DS2 Studios. The new design gave me hope when I didn't think it was possible and inspired me to love my dream again. You have a client for life!!



FARIVA C.

NURSERY DESIGN

DS2 designed my nurseries and I could rave about them all day. Working with Sarah was a dream, her professionalism and genuine desire to make my dreams into reality was remarkable. Her goal is literally to make her customers happy and make it a fun experience. She was extremely easy to work with and did the most beautiful job. She answered any questions immediately throughout the entire process and went beyond her services. Her quality of work is astounding and her substantial care for comfort is phenomenal. She did not just design, but turned our plain bedrooms into loving, comforting, happy and beautiful nurseries. I am so appreciative of her and her work and could not be happier! I recommend her to everyone, I promise you will be satisfied with her high-quality work! We absolutely love our nurseries and look forward to our next project, Thankyou Sarah!!!

DS2 STUDIOS

EXPERTS IN



RETAIL DESIGN



RESIDENTIAL
DESIGN



MULTI-FAMILY
DESIGN



HOSPITALITY
DESIGN

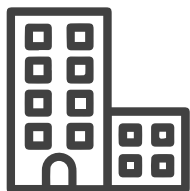

OFFICE DESIGN



EXTERIOR
DESIGN

TURN-KEY SERVICE

Turn-key services make up the bulk of what we do here at DS2 Studios, and for good reason! Once a client signs on to a move-in-ready install project, they can scratch interior design off their checklist. No stress. No hassle. Just complete, cohesive interiors designed to make THEIR project smooth and efficient. With superior project management solutions, and an invested interest in your space, we've got you covered!

DESIGN

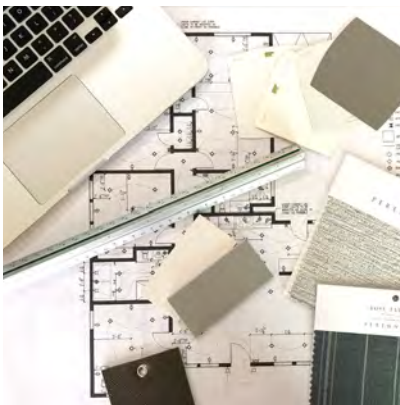

BUILD



INSTALL



GREAT FOR THE BUSY PERSON WITH LITTLE TIME TO DEVOTE TO CREATING THEIR DREAM INTERIOR.

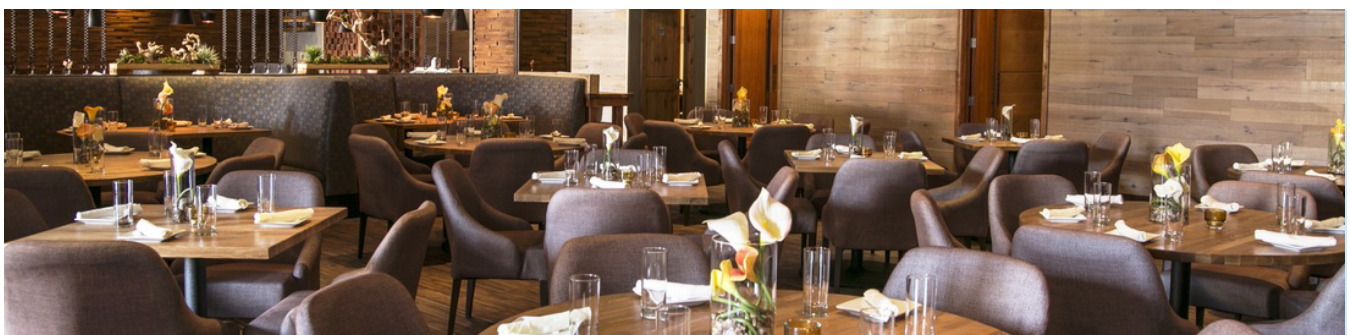

**Project management and installation rates are determined by a wide range of design and build factors. Contact us for a quote and free 20-minute phone consultation.

DESIGNER ON CALL SERVICE

Our designer on-call is a personal consulting service that helps business and home owners. We craft a beautiful cohesive design concept and let our clients execute the project on their own time with a complete roadmap to their dream space. This service lets our clients work with us via phone, text, or email whenever a question comes up during construction or design and they just need an expert to weigh in on the project, while simultaneously saving money.

MEET



DESIGN



DEVELOP



GREAT FOR THE PERSON READY TO MANAGE THEIR OWN PROJECT WHILE HAVING AN EXPERT IN THEIR POCKET.



E-DESIGN SERVICE

The E-Design service is our most affordable option for creating a cohesive look that fits your style and budget. A shopping list and concept layout give the client a plan for their space without having to hire a full-time designer. The shopping list is full of items that will make a space look beautiful and complete with a simple 2-step process. A 1-hour virtual meeting to discuss the project and a shopping list delivered directly to their email inbox.

MEET



SHOP



DELIVERED



GREAT FOR THE SAVVY SHOPPER WHOSE LOOKING FOR A QUICK DESIGN ALTERNATIVE, TO CREATE A COHESIVE SPACE.



CLIENT ON BOARDING

INITIAL CONSULTATION

- DEFINE DESIGN GOALS
- DISCUSS STYLE INSPIRATION
- EXISTING DESIGN CHANGES

PROPOSAL PACKAGE

- PRELIMINARY PROJECT INSPIRATION BOARD
- PROJECT TIMELINE
- PROJECT ESTIMATION
- COMPETITIVE ANALYSIS (HOSPITALITY PROJECTS)
- CONTRACT TERMS AND CONDITIONS



PROJECT PHOTO – BIZHAUS, COSTA MESA

DESIGN PROCESS

PACKAGE & PHASES

PROJECT PHOTO – BIZHAUS, EL SEGUNDO



DESIGN DELIVERABLES PACKAGE

- MOOD BOARD
- FLOOR PLAN
- ADDITIONAL PLANS (WHERE APPLICABLE)
 - LIGHTING PLAN
 - FINISH PLAN
 - DECOR PLAN
- 2D ELEVATIONS
- RENDERED ELEVATIONS (WHERE APPLICABLE)
- 3D MODEL & RENDERED IMAGES (SKETCH-UP OR PHOTO REALISTIC OPTION)
- DESIGN SELECTION BOARDS
 - FINISHES (WALL COVERING, FLOORING, TEXTURES)
 - FIXTURES (PLUMBING, ELECTRICAL, ETC.)
 - FURNITURE
 - ART & DECOR
- DETAILS
 - BUILT-INS
 - FURNITURE
 - CUSTOM DETAILS

DESIGN MEETING

- DESIGN PACKAGE PRESENTATION MEETING (VIRTUAL OR IN-PERSON)

EDITS & REVISIONS

- COLLABORATION CHANGES

FINAL PACKAGE

- FINALIZED DESIGN PACKAGE
- PRODUCT SPECIFICATIONS & NOTES
- SHOPPING LIST

DELIVERY & INSTALL

- PRODUCT PURCHASING AND DELIVERY
- ASSEMBLY & INSTALLATION
- ART & DECOR STYLING

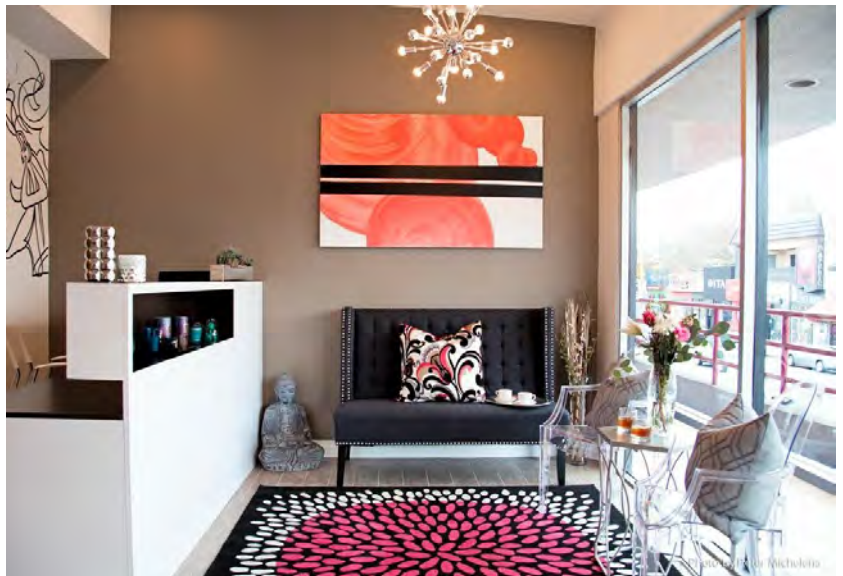

PROJECT PHOTO – ZENII SKIN & NAILS

GLOSSARY OF DELIVERABLES

IN CASE YOU'RE NEW TO THE PREVIOUS INTERIOR DESIGN TERMINOLOGY, HERE'S A QUICK RUN-THROUGH OF SOME OF THE AFOREMENTIONED SERVICE COMPONENTS & DESIGN DELIVERABLES.



PROJECT CONCEPT – LA HAIR

MOOD BOARD

A COLLECTION OF IMAGES, TEXTURES, PHOTOS, INTERIOR VIGNETTES, AND OTHER SIMILAR DESIGN INTEGRATIONS THAT WILL ACT AS THE INSPIRATIONAL FOUNDATION FOR THE PROJECT. THE MOOD BOARD ALSO INCLUDES THE AGREED-UPON COLOR PALETTE AND BRANDING SCHEMES THAT WILL BE PREVALENT THROUGHOUT THE DESIGN. THIS ENSURES A COHESIVE TONE IS UPHELD THROUGHOUT THE PROJECT.

FLOOR PLAN

ACTING AS THE SPATIAL BLUEPRINT FOR YOUR INTERIOR, THE FLOOR PLAN ENSURES THAT ALL PIECES FIT TOGETHER WITH ADEQUATE MOVEMENT PATHWAYS. FURNITURE, FIXTURES AND OTHER FUNCTIONAL DESIGN COMPONENTS ARE DRAWN TO SCALE AND THOUGHTFULLY ARRANGED WITH DEFINED MEASUREMENTS--MAKING INSTALLATIONS AND MOVE-IN DAYS A BREEZE!

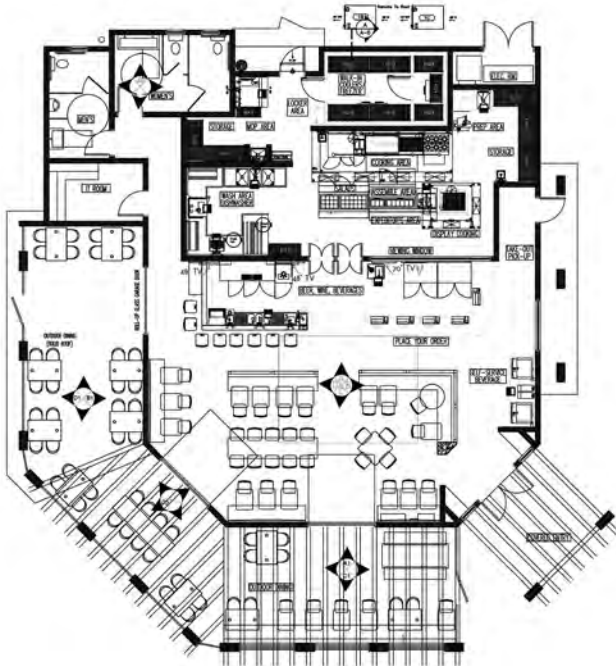

PROJECT CONCEPT – GREEN ACRES

LIGHTING PLAN

DETAILS HOW LIGHTING FIXTURES WILL BE DISPERSED THROUGHOUT THE SPACE, INCLUDING LAMPS, CHANDELIERS, PENDANTS, SCONCES AND BUILT-IN CEILING FIXTURES. THIS ENSURES ALL SPACES ARE WELL-LIT AND SUPPLIED WITH THE POWER NEEDED TO COMPLETE THE DESIGN.

FINISH PLAN

DETAILS WHERE FINISHES ARE LOCATED THROUGHOUT THE SPACE. THIS INCLUDES THE LAYOUT OF TILE, PAINT, FLOORING, WALLPAPER, ACOUSTIC PANELING AND OTHER MATERIALS. THIS ENSURES YOUR DESIGN CONCEPT IS INTEGRATED INTO THE VERY FOUNDATIONS OF YOUR COMMERCIAL INTERIOR.

DECOR PLAN

DETAILS WHERE ACCESSORIES ARE PLACED THROUGHOUT THE SPACE, INCLUDING WALL ART, THEMATIC PIECES, THROW PILLOWS, INTERIOR PLANTSCAPING, AND OTHER DECORATIVE OBJECTS. THIS ENSURES A NATURALLY-IMMERSIVE, COHESIVE ENVIRONMENT .

GLOSSARY OF DELIVERABLES CONT.

2D ELEVATIONS (RENDERED)

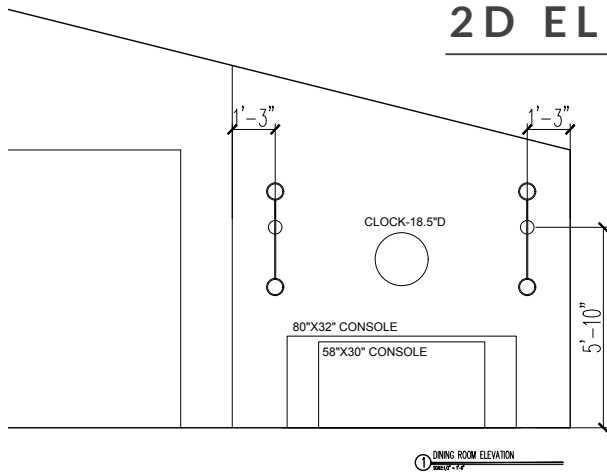

TWO-DIMENSIONAL DRAWINGS THAT NOTATE THE HEIGHTS AND SIZES OF ITEMS, AS THEY RELATE TO A WALL ON THE PLAN. THIS GIVE CLIENTS, DRAFTERS AND BUILDERS A HEAD-ON VIEW OF EACH WALL WITHIN THE SPACE. ELEVATIONS ALSO CALL OUT SPECIFIC HEIGHTS AND MEASUREMENTS FOR COUNTERS, WINDOWS, HANGINGS AND OTHER WALL-ORIENTED OBJECTS.

ADDITIONALLY THE ELEVATIONS CAN BE RENDERED WITH THE SELECTED FINISHES, TO SHOW HOW THEY ARE APPLIED TO THE WALL.



PROJECT CONCEPT – GREEN ACRES

DESIGN SELECTION PACKAGE

THIS IS A MODERN SAMPLE BOARD. WITH PHOTOS OF THE PROPOSED FINISHES AND FIXTURES, TO GIVE THE CLIENT THE LOOK AND FEEL OF THE CHOSEN ITEMS, AND HOW THEY WILL LOOK ALL TOGETHER IN THE SPACE.

THESE BOARDS WILL INCLUDE PHOTOS OF ANY FINISHES, FIXTURES OR ART AND DECOR AS THEY RELATE TO THE PROJECT ROOM OR SPACE.

Materials

SELECTION BOARD

1. VINYL FLOOR
2. COUNTER TOP & TUB WALL/SURROUND (PIETRA)
3. CABINET FINISH (WHITE-OAK)
4. SHOWER WALL TILE
5. SHOWER FLOORS
6. NICHE ACCENT TILE
7. SINK FAUCET
8. SINK
9. SHOWER FAUCET
10. TUB FILLER
11. TOILET
12. VANITY WALL SCORCE
13. MIRROR (BLACK)
14. CABINET PULL (4")
15. CABINET KNOB

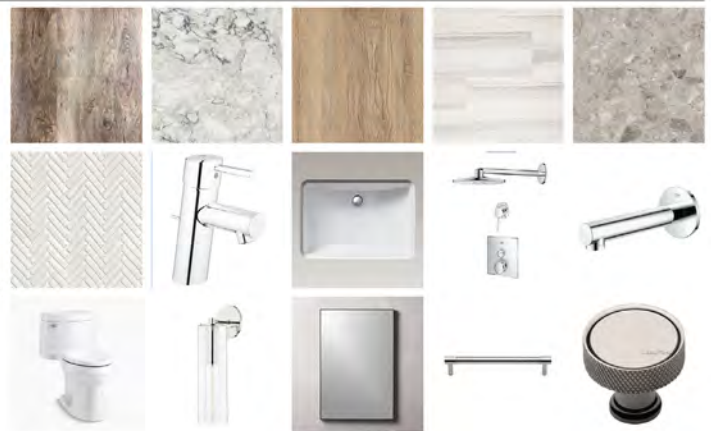

RESIDENTIAL BATHROOM DESIGN - GROUND-UP BUILD

GLOSSARY OF DELIVERABLES CONT.

3D MODELS & RENDERINGS

THREE-DIMENSIONAL CONCEPTS GIVE A MORE COMPLETE PERSPECTIVE OF THE FINAL DESIGN AND THE SIZE OF THE SPACE. ONCE ALL SELECTIONS, FINISHES AND ELEVATIONS ARE COMPLETE, THEY ARE SENT TO A TEAM OF PROFESSIONAL GRAPHIC ARTISTS WHO CREATE A VIRTUAL RECREATION OF YOUR INTERIOR. (SKETCH-UP OR PHOTO REALISTIC) OPTIONS AVAILABLE



PROJECT CONCEPT – MARVISTA RESIDENCE



PROJECT CONCEPT – GREEN ACRES



PROJECT CONCEPT – VENTURA CONDO

CUSTOM DESIGN DETAILS

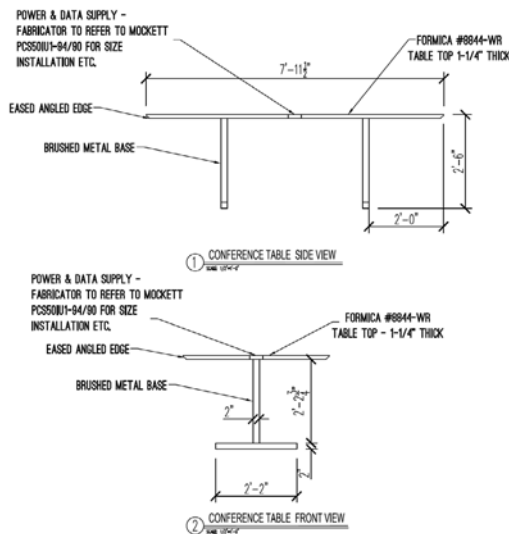
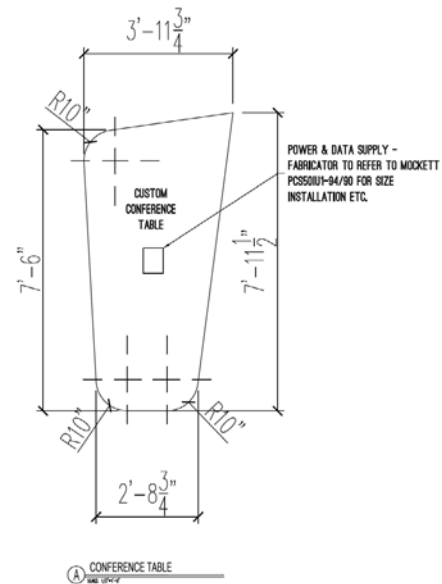

CUSTOM FURNITURE, AND BUILT-IN DESIGNS REQUIRE MORE INFORMATION FOR QUOTES AND BUILDING.

THESE DRAWINGS GIVE THE TEAM A THOROUGH EXPLANATION WITH CALL-OUTS TO FINISHES, ANY NECESSARY POWER OR PLUMBING NEEDS, DIMENSIONS, AND ANY DESIGN SPECIFIC REQUIREMENTS TO FINALIZE THE PIECES.

GLOSSARY OF DELIVERABLES CONT.

SAMPLES

WE WILL MAIL OR DROP OFF ALL PHYSICAL SAMPLES TO THE PROPERTY, FOR FINAL APPROVAL AND SIGN OFF, PRIOR TO ORDERING.

THIS GIVES THE CLIENTS A CHANCE TO TOUCH AND FEEL THE MATERIAL AND CONFIRM THE FINISH OF A MATERIAL MEETS THEIR EXPECTATIONS. IT ALSO HELPS IF THERE ARE ANY SCREEN DISCOLORATION ISSUES.



PROJECT SAMPLES- VENTURA CONDO

FINISH SCHEDULE OR SHOPPING LIST

DEPENDING ON THE THE PROJECT THERE WILL EITHER BE AN F.F.E. (FURNITURE, FIXTURES, EQUIPMENT) LIST OR AN ITEMIZED SHOPPING LIST.

F.F.E.







F.F.E. ARE IDEAL FOR PROJECTS THAT REQUIRE CONSTRUCTION AND OR HAVE A CONTRACTOR, THEY HAVE ALL THE SPECIFIED FIXTURES AND EQUIPMENT INFO AS IT RELATES TO THE PROJECT LISTED WITH QTY, PRODUCT SPECS, SIZES, SKU ETC. WHICH HELPS THE TEAM CREATE MORE ACCURATE PROJECT BIDS AND AVOID COSTLY CHANGE ORDERS.

CABINET HARDWARE		ROUTED FINGER PULL ACROSS ALL LIPS						
SHOWER WALLS		RESPOSANI	ECCOALBERTO	GREY	1200	\$4.00		LINK
TUB FILLER		KOHLER	TBO	BLACK				
SHOWER BENCH		SANDON	LAGOON	POLISHED				
SHOWER HEAD		KOHLER	K-72419-G-01	BLACK			1	LINK
SHOWER CONTROLS		KOHLER	TBO	BLACK			1	
BATH TUB		KOHLER	K-1071-0	WHITE	60X30X29	\$1,104.95	1	LINK
TOILET		TOTO	M5041ACFSGH1	COLONIAL WHITE	60X30X22	\$1,104.36	1	LINK
VANITY LIGHT BAR		SONNEMAN	K-1821-0	BLACK	6	\$1,000.00	1	LINK

GLOSSARY OF DELIVERABLES CONT.

SHOPPING LIST

A CLIENT SHOPPING LIST IS PERFECT FOR A REDECORATING PROJECT OR THE DIY CLIENT WHO PLANS TO HIRE A HANDY MAN TO EXECUTE THE PROJECT. THESE LISTS COMPILE ALL THE FURNITURE, ART, AND DECOR WITH LISTED SPECS AND SHOPPING LINKS SO THE CLIENT CAN PURCHASE THE PRODUCTS AT THEIR LEISURE. THIS ALSO GIVES THEM DIRECT ACCESS TO THE PRODUCTS WITHOUT HAVING TO GO THROUGH THE DESIGN COMPANY AND PAYING A MARK-UP.

ITEM	QTY	RATE	TOTAL
 Butterfly Chair Room: Living Room LINK TO BUY: https://bit.ly/3ez2N3N	1	\$129.99	\$129.99
 Side Table Room: Living Room LINK TO BUY: https://bit.ly/2Uw088a Dimensions: 12.5 x 12.5 x 20 inches	1	\$71.10	\$71.10
 Metal Bar Cart Room: Living Room LINK TO BUY: https://bit.ly/3nQJfGL	1	\$150.00	\$150.00
 Dining Bench Room: Dining Room LINK TO BUY: https://bit.ly/3BfKf9q	1	\$190.00	\$190.00
 Dining Table Room: Dining Room LINK TO BUY: https://bit.ly/3Bf0aP6	1	\$369.99	\$369.99
 Dining Chair Room: Dining Room Oak Wood LINK TO BUY: https://bit.ly/3eGf9Dj	2	\$79.47	\$158.94

PROJECT TIME-LINE

A PROJECT TIMELINE BASED ON DATES OF PROJECT ON-BOARDING.

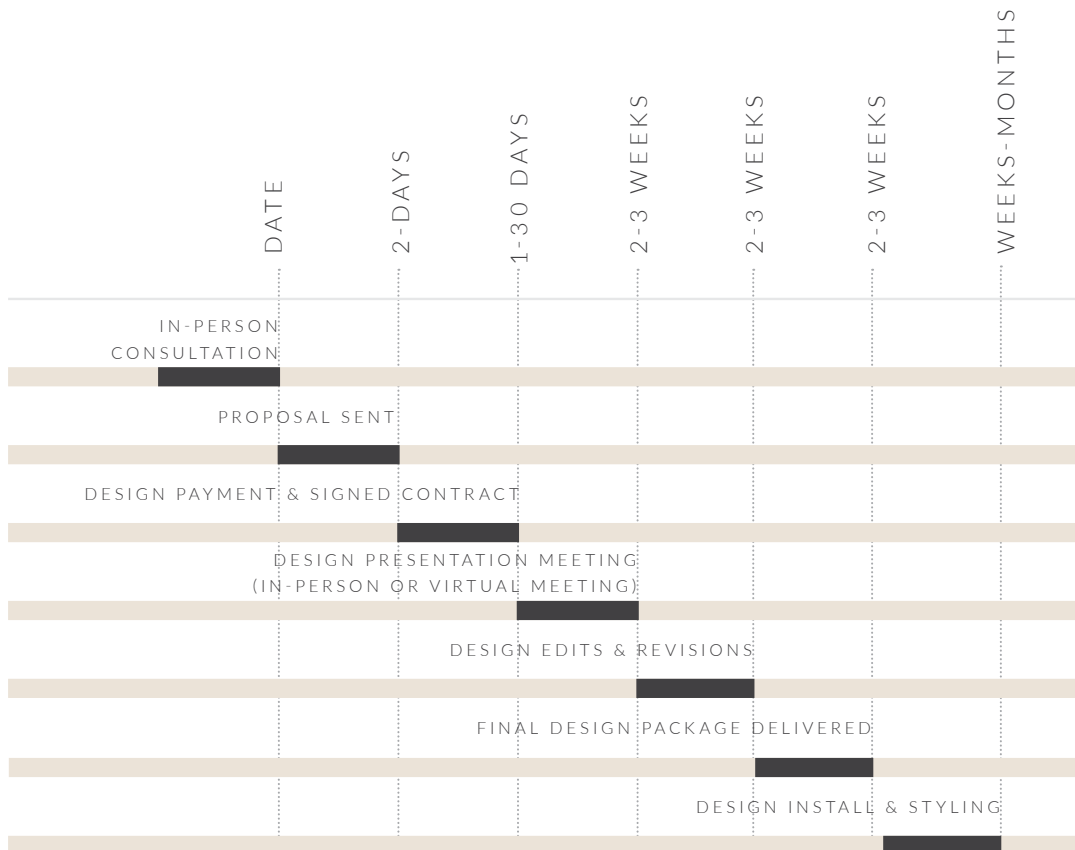

*DATES ARE ESTIMATED BASED ON SIGNED PROPOSAL, PAID INVOICES, PRODUCT LEAD TIMES, AND PROJECT CONSTRUCTION.

GLOSSARY OF DELIVERABLES CONT.

PROJECT ESTIMATOR

CREATE A BETTER OVERVIEW FOR A PROJECT WITH BUDGETED LINE ITEMS TO GIVE INSIGHT FOR POTENTIAL COST, PRICING IS DETERMINED BY SQ.FT AND PROJECTED IMPROVEMENTS DISCUSSED AT THE INITIAL IN PERSON CONSULTATION. THESE ARE GREAT FOR COMMERCIAL CLIENTS WITH MULTIPLE INVESTORS OR HOME OWNERS WHO HAVEN'T HIRED A CONTRACTOR AND WANT TO GET A BETTER SENSE OF WHERE THEIR BUDGET WILL GO THROUGHOUT THE JOB.

DESCRIPTION	COST (\$)
INTERIOR	\$TOTAL
FURNITURE	\$0.00
FIXTURES	\$0.00
FINISHES	\$0.00
ART, DECOR, ACCESSORIES	\$0.00
EQUIPMENT	\$0.00
INSTALLATION	\$0.00

COMPETITIVE ANALYSIS REPORT

A COMPREHENSIVE ANALYSIS OF OUR COMMERCIAL CLIENT'S LOCAL COMPETITION, DETAILING THE COMPARATIVE AMENITIES, AESTHETICS, BRANDING STYLES, TARGET DEMOGRAPHICS AND OTHER POINTS OF INTEREST RELEVANT TO OUR CLIENT'S INTERIOR DESIGN. EACH REPORT IS THOROUGHLY RESEARCHED BEFORE ANY OF OUR CLIENT'S DESIGNS ARE PUT TO PAPER. THIS ENSURES OUR CLIENT'S INTERIOR IS FUNCTIONAL, PURPOSEFUL AND RECOGNIZABLE BY TAKING ADVANTAGE OF THE CURRENT PLAYING FIELD.

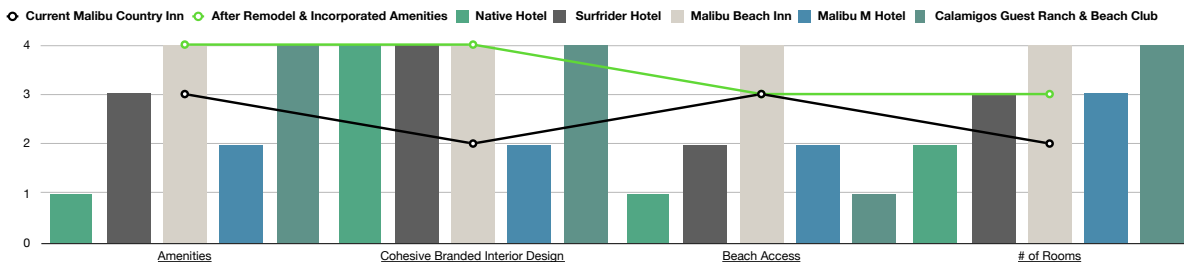

PROJECT COMPARISON - MALIBU COUNTRY INN

PRICE SCHEDULE

FRESH DESIGNS AT BETTER PRICES AND
A FASTER TURN-AROUND.

STARTING AT \$20K	TURN-KEY
	Full project flat fee start to finish service starting at 20k.

DESIGNER ON CALL	\$300/HR
Hourly design packages with min. 20Hr	

\$500/ROOM	E-DESIGN
	1-room e-design & consultation.

1 ON 1 CONSULTATION	\$350/HR
By the hour design consulting.	

ADDITIONAL SERVICES AVAILABLE	RATE (\$)
• Project Construction & Management Meetings	\$ 350 /HR
• Product Purchasing, Installation & Delivery	\$ 200 /HR
• Project Site Meetings	\$ 350 /HR

READY TO GET STARTED?

CONTACT US FOR A FREE 20-MINUTE PHONE CONSULTATION.

P:(323)902-7088 | E:HELLO@DS2STUDIOS.COM | W:WWW.DS2STUDIOS.COM

THANK YOU FOR
CONSIDERING
DS2 FOR YOUR
NEXT PROJECT

DS2

STUDIOS

DS2 STUDIOS

VENTURA, CA

PHONE. 323.902.7088

EMAIL. HELLO@DS2STUDIOS.COM

WWW.DS2STUDIOS.COM

